

RuleV

Please Read:

These are the rules and regulations for the LS Fest Drift Challenge. Although we try our best to avoid updates midseason, they may occur. Please verify you are using the most current version when reviewing throughout the season.

NOTE: This rulebook is not as in depth as the Formula DRIFT Professional Rulebook. This rulebook should not lead you astray, however the Formula DRIFT rulebook is updated more frequently than ours and we may not catch every update and/or change they make. If you eventually plan on competing in Formula DRIFT, please take the time to familiarize yourself with their rulebook in addition to ours, so you can plan your build out accordingly and save yourself both valuable time and money. If you have any questions, feel free to contact Nick Swann at nick@mdudrift.com

1. Closed face helmet is required. SA2010 or newer helmets are required. Helmet must be in good condition and show no signs of damage. Chin strap must be present and fastened. Open face helmets are not allowed. M (motorcycle) helmets are not allowed. DOT helmets are not allowed.

2. All drivers are required to wear long pants, closed toe shoes and sleeved shirts. Long sleeve shirts are not required.

A. Tandem Drivers: In addition to the aforementioned requirements, tandem drivers are required to wear a "racing suit" which must be made of fire resistant material and certified to SFI spec 3/2 or greater or homologated to "FIA 2000" specs, which effectively covers the body, including neck, ankles, and wrist.

3. Pit area must be kept clean of all trash at end of event. All used tires must be taken with you at the end of the event.
4. If you spill any automotive fluids, you must clean it up immediately. Notify the staff of any spills. Most of the tracks that we operate at have facilities for the disposal of automotive fluid. DO NOT dispose of any motor oil, antifreeze, and gear oil in the trash cans.
5. Driver must be 17 or older and possess a valid driver's license. If under 18, parent or legal guardian must be present and sign waiver (please see staff).
6. Driver's meetings are mandatory. If you do not attend the driver's meeting without making prior arrangements, you will not be allowed on track. No refunds will be given.
7. Passengers are not allowed in cars on track. If a driver brings a passenger, they will be sent directly off track and can return to the back of the line after they drop off their passenger.
8. Common sense is required.
9. Driver must be ready to rock at all times. STAY ALERT!
10. No whining. You can always pack up and go home.
11. Drivers must pay very close attention to all flaggers and course workers. If any of their instructions are ignored, the driver will be, at a minimum, kicked off the track for the session. If the offense is repeated or unsafe, the driver will be ejected from the event. No refunds will be given.
12. Each individual participating in a Holley event shall conduct themselves in a professional manner at all times, especially with other drivers and Holley staff, and in a manner that is in no way detrimental to the reputation of Holley. Drivers are responsible for the conduct of their crew members and anyone else accompanying them to the event. Any offense committed by these individuals will be charged directly to the driver. Failure to follow the rules or any instruction from racetrack staff may result in immediate ejection from the event and (depending on severity of offense) cause you to be banned from any or all future events hosted by the group at all tracks.

Vehicle Requirements

General Safety

1. General vehicle Inspection may include inspection of brakes, suspension, engine, drivetrain and chassis for proper operation, condition, and potential issues.
2. Everything loose in car must be removed, includes floor mats, dirty clothes, old cd cases, empty packs of smokes, cans and anything else floating around in your car.
3. Fire extinguishers are required for all cars. Fire extinguishers must be securely mounted within reach of driver while in seat with harness on. Driver must be able to remove it easily for use. Minimum 2lb required. **NO SHARING WITH FRIENDS, YOU MUST HAVE YOUR OWN. THEY ARE ONLY \$20.**

Technical Inspection:

1. No fluids can be leaking or dripping from the car. If signs of a fluid leak are present, evidence must be shown that leak no longer exists.
2. Heat shield is required around the brake and clutch master cylinders for any cars with the exhaust side of the engine on the same side as the driver. OE heat shield is acceptable. ***Bent up license plates or other painted/coated surfaces are not acceptable.***
3. Coolant overflow is required on all cars. Oil overflow is required on cars which have removed or modified OE oil recovery system. Antifreeze may not be used. Only water or a mixture of water and heat transfer additives may be used.
4. A gas cap must be present and be completely sealed. A firewall is required for all fuel system components inside the driver's compartment. Stainless steel braided lines can pass through driver's compartment, but all fittings and unions must be behind firewall or be similarly shielded.
5. All fluid hoses must be the proper hose to use for the install application and purpose. All hoses must have correct material and construction. Rubber hoses should show no sign of wear or weak spots. All fuel hoses must use fuel line clamps. Worm gear

clamps are not allowed on fuel lines.

6. The exhaust must be present and exit outside of the body of the car.

Lighting and Electrical:

1. The battery must be securely tied down with a plastic or metal strap and proper hardware. No bungee cord, zip ties, etc. are allowed.
2. If the battery is located in driver's compartment, the battery must be sealed and non-venting. Non-sealed batteries are allowed in driver's compartment if it is in a fully sealed box, properly mounted and vented outside the car.
3. Brake lights must be operational. At least 2 brake lights must come on when using the brake pedal.
4. Hazard lights at front and rear of the car must be operational. The hazard switch must be located in the cabin and within reach of the driver while they are strapped into seat.
5. An OE key must completely shut off the car immediately. If the OE key assembly is not used, a kill switch must be used to immediately shut off the car. The kill switch needs to be easily accessible from outside of the car and the location needs to be clearly marked "KILL SWITCH."
6. All wiring should be protected, insulated and properly mounted.

Suspension:

1. Ball joints and suspension bushings must be in good condition and have no excessive play or clunking.
2. Wheel bearings must have zero play.
3. Steering must be smooth in operation and exhibit no binding.
4. All lug nuts must be present and properly torqued and have proper thread engagement. If using bolt on spacers, all lugs nuts attaching the spacer to the hub must be present.

Body and Glass:

1. Body panels are required. Body panels include the fenders, hood, and hatch/trunk. Due to the nature of drifting, bumpers and side skirts are not required at all times, although they are highly recommended during competition.

2. Tow hooks/straps are required front and rear. Factory tow hooks are allowed as long as the driver accepts that their car may be damaged when being towed. Tow hooks/straps should be easily found and painted a highly visible color and their location marked. Soft tow straps are recommended. Please label TOW on your car.

3. All hoods must have hood pins! OEM latch is optional, but hoods must be secured using a minimum of 2 hood pins mounted within 24 inches of the leading edge of the hood. Hood pins must be equally spaced.

4. The windshield, rear window and fixed side windows must be present. Door windows must be operational if installed. Lexan or similar shatter resistant polycarbonate can be used. Lexan windshields need to be 1/4" thick. Lexan windshields must have center supports and must be bolted or riveted through the window frame. Spacing is a maximum of 12" and there must be at least 4 fasteners on each side. Side and rear windows need to be 1/8" thick.

Roll Cage:

A roll cage is not required to participate in any event. However a roll cage is required to tandem and compete.

Construction Materials: Roll cages may be constructed of either Seamless Mild Steel (DOM) or Seamless Chromoly (4130) tubing appropriately sized for the weight of the vehicle. Mild Steel (ERW) is not permitted.

Tubing Diameter: Tubing diameter is determined by the weight of the vehicle, race prepped, minus driver and fuel. IE: Up to 3500 lbs - 1.500" x 0.095" Chromoly (4130) or Mild Steel (DOM)

Mounting Points: The roll cage shall be mounted to the floor of the chassis in at least six

(6) points with either plates or boxes. All attachment points must be mounted to these plates or boxes and be welded three-hundred sixty (360) degrees. Mounting plates can be no smaller than two (2) inches on any side and have a minimum thickness of 0.080".

Mounting Points - Bolt in the cage - The roll cage shall be fastened to the floor of the chassis in at least six (6) points.

The attachment points of a bolt-in cage to the body must use plates, 3/16 inch thick minimum, to sandwich the body. A minimum of three (3) bolts are required per mounting plate. Each plate must be at least 3/16 inch thick. All hardware must be at

least SAE Grade 5 or better and be a minimum of 5/16 inch diameter. All nuts must be held securely by safety wire, lock washer, nylock, or jam nut.

Welds: All welds must conform to the American Welding Society D1.1:2002, Structural Welding Code, Steel Chapter 10, Tubular Structures. All welds shall be continuous, three hundred sixty (360) degrees, around each mounting point of each tube. All welds shall be visually inspected and must meet the following criteria in order to be acceptable.

1. All welds shall be free of any cracks
2. Thorough penetration must exist between the tube and base material.
3. All craters, if any shall be filled to the cross section of the weld.
4. Undercut shall be no more than 0.01 inch deep.

Inspection Hole: All tubes must have a 3/16 inch, but no greater than 1/4 inch, hole drilled in a non-critical area as to verify wall thickness.

Bends: No part of any tube shall show signs of crimping or wall failure. All bends must be mandrel bends, crush bends are not accepted.

Main Hoop: The roll cage main hoop should be constructed from one continuous length of tubing and be as close to the full width of the interior and as close to the roof as possible with no more than four (4) bends totaling no more than one hundred eighty (180) degrees +/- ten (10) degrees.

Diagonal Brace: At least one (1) diagonal brace shall be used during construction of the main hoop. The diagonal should be in one continuous path. Refer to diagram 1.0 One end should attach to the mounting plate, or main hoop as close to the mounting plate as possible, diagonally opposed to the drivers head. The other end shall mount to the corner, or horizontal part, of the main hoop about the drivers head, within twelve (12) inches of the driver's side corner. It is recommended the diagonal brace be one continuous length of tubing.

Diagram 1.0

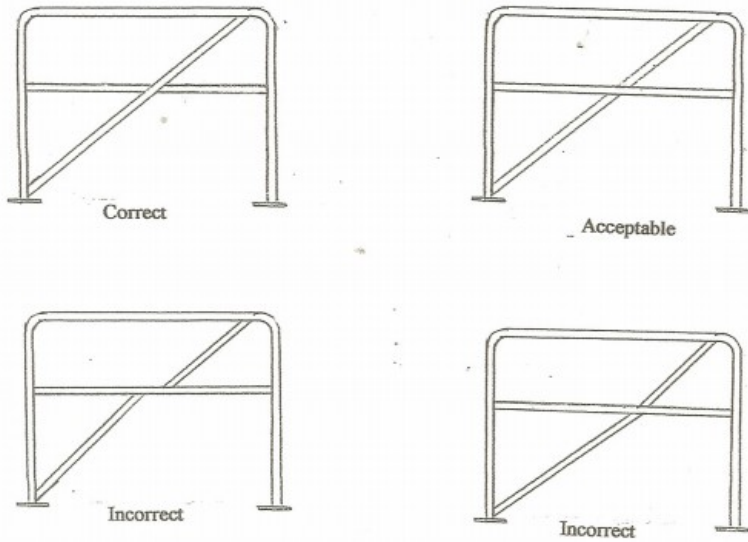

Harness Bar: The main hoop shall contain a horizontal mounted harness bar, which is to be constructed of like material, and be located no higher than shoulder height. The harness bar must extend from each leg of the main hoop and intersect the diagonal brace.

Front/Side Hoops/Halo - All hoops and/or down tubes must be mounted to the floor, as forward as possible, and following the "A" pillar and door frame back to the main hoop. There shall be a tube connecting each of the two (2) side hoops at the top of the windshield mounted as close to the roof as possible. Each side hoop shall contain no more than four (4) bends totaling no more than one-hundred eighty (180) degrees.

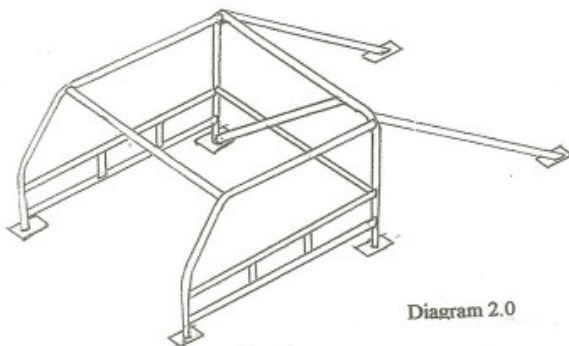
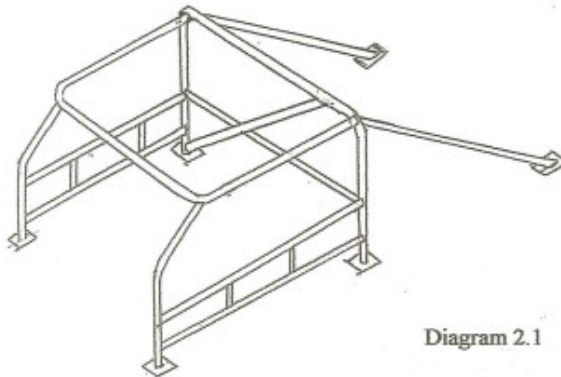
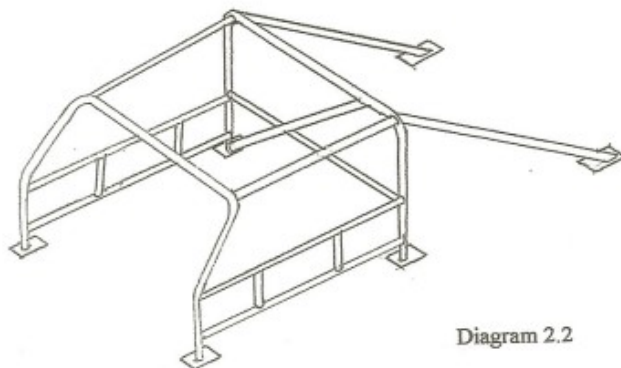

Diagram 2.0

Halo Hoop: A Halo Hoop is one (1) continuous length of tubing. The halo extends from the main hoop, in a forward direction, following the roof line about the doors and windshield. The halo must be connected to the floor with two (2) front down tubes. The Halo bar must not contain more than four (4) bends totaling no more than one-hundred eighty (180) degrees.



Front Hoop: A front hoop is one (1) continuous length of tubing. Starting at the floor, as far forward as possible, and then following the “A” pillar up to the roof. Then, following the roof, windshield line across the vehicle and down alongside the other “A” pillar to the floor. No more than four (4) bends totaling no greater than one hundred eighty (180) degrees will be permitted. The front hoop must be connected to the main hoop by means of two (2) horizontal bars, one (1) on each side above the doors.



Rear Braces: The main hoop must have two (2) braces extending to the rear. The braces must attach as near to the top of the main hoop as possible and no more than six (6) inches below the top. The rear braces must not contain any bends. There must be a minimum of thirty (30) degrees between the rear braces and the main hoop.

Diagram 3.0 When viewed from the top the rear braces are to form no more than a one-hundred five (105) degree angle Diagram 3.1 and no less than a seventy-five (75) degree angle.

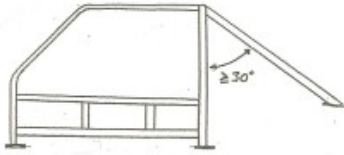

Diagram 3.0

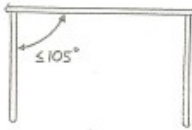

Diagram 3.1

Main Hoop Top View

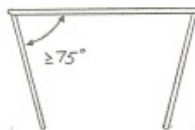

Diagram 3.2

Main Hoop Top View

Door Bars: All cars are required to have at a minimum two (2) bars across each front door opening. The door bars may run parallel to one another or form an "X". Diagram 4.0 If a parallel design is used a minimum of two (2) vertical bars must be installed, joining the upper and lower bars.

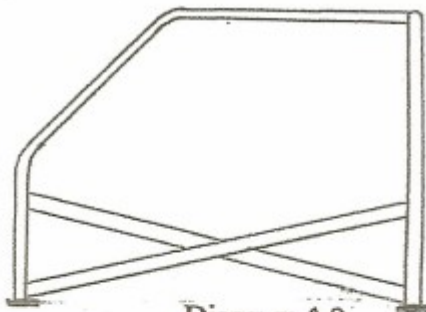

Diagram 4.0

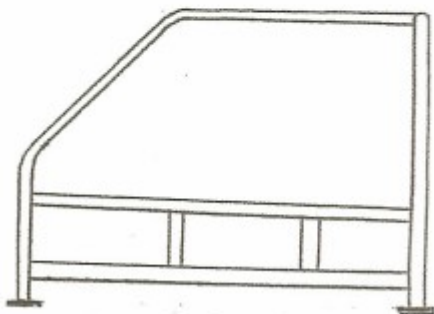

Diagram 4.1

Padding: All roll cage surfaces that may contact the driver should be padded with high-density padding. It is not required though recommended that all padding meet SFI specification 45.1 **Drivers that fail to follow this rule will not be eligible to tandem.**

Roll Cage FAQ:

1. Aftermarket roll bar, at a minimum, is required for all convertibles for road course events. For parking lot events, if no roll bar is present, roof must be up and properly fastened.
2. 6-point roll cage with harness bar and door bars required for Group A.
3. Roll cage must have X or NASCAR bars on both front doors.
4. Must have diagonal in main hoop extending from above driver's head to passenger floor and harness bar must extend the full length of the main hoop and be positioned for proper harness mounting.
5. Rear mounting bars must tie in at the rear shock tower.
6. Front cage design can be halo or a-pillar bars. Roof bar is required if using a-pillar bars.
7. Dash bar is recommended but not required.
8. Minimum tubing specification for all cars is 1.5"x0.095 DOM SAE 1018.
9. Cage must comply with current SCCA/NASA specification.
10. For bolt-in cages, OE crash structure cannot be removed or modified. Ebay or "Tuner" bolt-in cages are not sufficient for tandem.
11. Roll bar padding is required wherever the driver or passenger may come in contact with the roll cage, i.e. halo, door bars, lower a-pillar bar. Roll bar padding can be any type of foam padding designed to be used for this purpose. No pool noodles, home depot pipe insulation, etc. SFI rated padding is recommended but not required.

Harnesses and Seats:

1. Harnesses must be properly mounted and not expired. Harnesses must be FIA or SFI rated and within the date range specified on the belts.
2. Harnesses must be mounted using correct hardware. If using eye bolts and bolting through the floor, must use fender washers on both sides to spread the load. Harness shoulder straps must be mounted to a roll cage or separate harness bar and should not be outside of 20° of horizontal. The seat cannot be used as a guide for the harness. No harness mounting points can be attached to the seat or seat rails, they must be attached to the chassis.
3. If car does not have a roll cage, a harness bar can be used to mount the shoulder belts when using a 4, 5 or 6-point harness. Must meet mounting requirements listed in item 2.
4. 4, 5 or 6-point harness required for car with a roll cage installed. 5-point belt recommended.
5. If harnesses are not properly installed and in compliance with FIA or SFI specifications, you will not be allowed to drive until this rule can be met.
6. Please refer to manufacturer's specs for proper installation and maintenance procedures.
7. If stock seats or non-FIA approved reclinable bucket seats are used, stock seat belt must be used. Aftermarket harnesses are not allowed to be used with these seats.
8. If race seats are intended to be used with stock seat belt, the lap belt part of the seat belt must pass through the holes in the side of the race seat.
9. If the driver chooses to drive without side windows or with side windows down, arm restraints or a window net must be used, NO EXCEPTIONS! Competitors with a convertible vehicle must use arm restraints.
10. All drivers must be able to exit their car within 10 seconds in an emergency situation. Holley Staff reserves the right to test for this on grid at any point in the day. If the driver cannot meet these standards, the car will be deemed unsafe and the driver will not be able to drive until they can meet this standard.